

42BYG1.8° 两相步进电机 2-Phase Stepping Motors

一般规格 General Specifications

项目 Item	规格 Specifications
步进角精度 Step Angle Accuracy	±5% (full step, no load)
温升 Temperature Rise	80°C Max.(rated current, 2 phase on)
环境温度 Ambient Temperature	-10°C - +50°C
绝缘电阻 Insulation Resistance	100MΩMin.500V DC
绝缘强度 Dielectric Strength	500V AC for one minute



技术规格 Specifications

型号 Model	相电压 Phase Voltage	电流 Current	电阻 Resistance	电感 Inductance	最大静转矩 Holding Torque	定位转矩 Detent Torque	转动惯量 Rotor Inertia	重量 Weight	尺寸 Size		
									L mm	L1 mm	L2 mm
42BYGH613-01B	V	A	Ω	mH	Nm	g.cm	g.cm ²	Kg			
	2.4	1.7	1.5	3.2	0.4	220	54	0.24	40	14	300

外型尺寸: FIGURE DIMENSIONS unit=mm

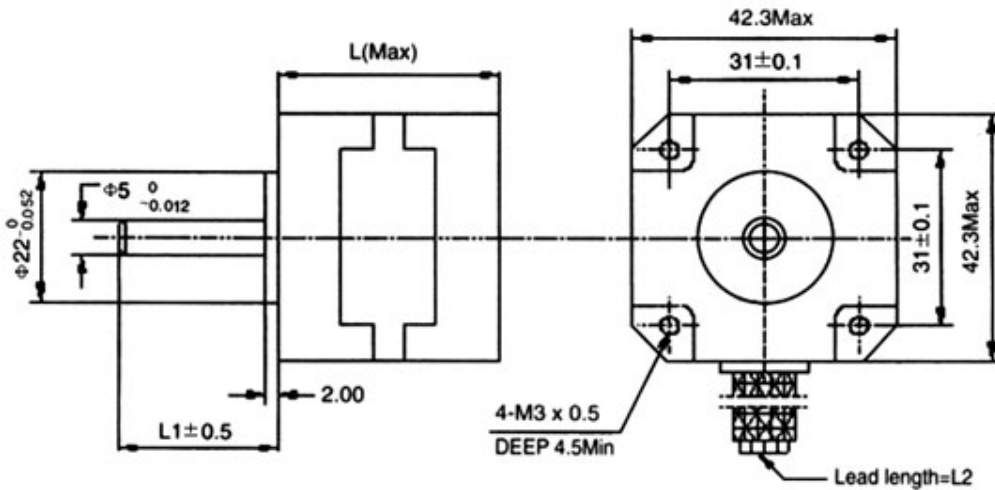

接线图 Wiring Diagram:

